



BRAKE DISK INFRARED TEMPERATURE SENSOR INFKL-800

Aluminium housing

Dimensions 20 x 18 x 12 mm

Weight 26 g

Range	800°C
Supply	5 Volts
Output	0.5 V to 4.5 V
Sensitivity Signal	5 mV/°C 0.5 V at 0°C 4.5V at 800°C
Accuracy	3 % FS
Response time	100 ms
Supply current	1.5 mA

IR Wave length	8 to 14 µm
Emissivity	99%
Calibrator	Land R1200P
Protection	IP 64
Vibration Test	20 Gpp 5'
Shocks	1000 G
Operating temperature	0 to 60°C
Storage Temperature	-40 to + 125°C

Measurement distance : 30 to 70 mm **Field of view :** 2.5 : 1

Spot size : 20mm diameter at 50mm distance

Connection : 1 meter of 3 x AWG26 PTFE shielded cable

Connector : without

Couleur Fil	Fonction	Contact / Pin
Rouge / Red	5 V	
Blanc / White	Signal	
Bleu / Blue	0 V	

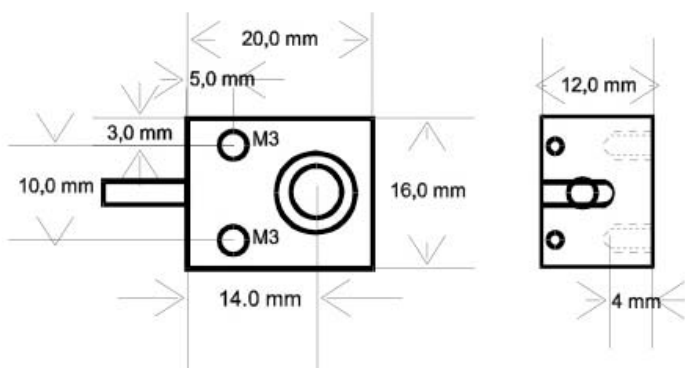
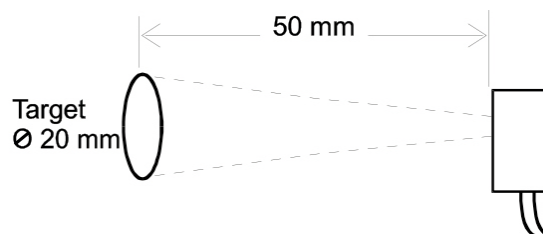

**TEXYS
INTERNATIONAL**

ZA des Chamonds
Rue Edouard Branly
58640 Varennes-Vauzelles
(FRANCE)

Tel. : +33 (0) 3 86 21 27 18

Fax : +33 (0) 3 86 21 24 49